



## Quad-Core Intel® Xeon® Processor 5400 Series

Boost Performance and Energy  
Efficiency with new 45nm multi-core  
Intel® Xeon® processors



## More Innovation – Improved Value

Now featuring Intel's second-generation quad-core processor, existing mainstream server platforms, new high-performance computing (HPC) systems, new workstations, and new business servers each deliver a unique combination of technology targeted at specific IT use environments. By selecting a platform that is best tuned for the most common IT usages, Intel® servers are able to better optimize return on investment while extending the leading performance and performance-per-watt advantages enjoyed when using Intel's proven multi-core technology. Quad-Core Intel® Xeon® processor 5400<sup>Δ</sup> series help provide your data center or business with the performance headroom needed to confidently consolidate applications onto fewer systems using proven virtualization solutions or the compute power necessary for high-performance computing applications and workstation solutions.

### Platforms that Optimize Return on Investment and Increase Performance

Intel delivers much more than just fast servers. With platform enhancements such as 45nm technology, Intel® Virtualization Technology<sup>1</sup> (Intel® VT), and an L2 cache that's 50% larger, a technology infrastructure built with Intel® Xeon® processor-based platforms improves your return on IT assets while also helping to make your company more efficient, responsive, and competitive.

### Innovation that Breaks the Performance Barrier

New Quad-Core Intel Xeon processor 5400 series-based servers, HPC systems, and workstations are built with 45nm enhanced Intel® Core™ microarchitecture, previously code-named "Penryn." The Intel® 45nm technology uses high-k dielectric materials that are expected to fuel the ongoing performance advantages predicted by Moore's Law for years to come, and significantly increases the transistor density over the previous Intel® 65nm technology. Intel's 45nm packs 820 million transistors into the Intel Xeon processor 5400 series over the previous-generation Intel® Xeon® processor 5300<sup>Δ</sup> series, which had an astounding 582 million transistors.

More transistors means more capability, performance and energy efficiency from enhancements that include expanded power management capabilities, enhancements designed to reduce virtualization overhead and 47 new Intel® SSE4 instructions which can help improve the performance of media and high-performance computing applications.

### Built for Virtualization

Quad-Core Intel Xeon processor 5400 series-based server platforms deliver incremental headroom and performance for your two-processor general-purpose server, so you can confidently consolidate applications onto fewer systems with fewer cooling challenges, giving you more performance per square foot.

Platforms have integrated virtualization hardware support with Intel Virtualization Technology, which enables more efficient virtualization solutions. Intel VT works by hardware assisting your virtualization environment and, in combination with powerful, reliable Quad-Core Intel Xeon processor 5400 series-based servers, boosts asset utilization and IT flexibility while reducing costs and data center power consumption. And new enhancements to Intel VT coupled with 45nm technology speed up virtual machine transition (entry/exit) times between 25 to 75 percent.

With the new Intel Xeon processor 5400 and 5200<sup>A</sup> series offering maximum flexibility, IT managers can now build one compatible group of platforms for live migration across all of their Intel Core microarchitecture-based servers including 2P Dual-Core Intel® Xeon® processor 5100<sup>A</sup> series-based servers, 2P Quad-Core Intel Xeon processor 5300 series, and the scalable 4P Quad-Core Intel® Xeon® processor 7300<sup>A</sup> series.

The ability to conduct live VM migration offers tremendous flexibility for fail-over, load-balancing, disaster-recovery, and real-time server maintenance scenarios. And thanks to a new feature called Intel® VT FlexMigration, IT will have the capability to add new Quad-Core Intel Xeon processor 5400 series and future Intel Xeon processor-based systems to the same resource pool when using future versions of virtualization software. This gives IT the power to choose the right server platform to best optimize performance, cost, power and reliability. These processor enhancements are further supplemented by:

- Intel® VT FlexPriority, a new Intel® VT extension that optimizes virtualization software efficiency by improving interrupt handling<sup>2</sup>
- Virtual Machine Device Queues (VMDq), which sort data through multiple queues in the silicon, resulting in efficient network processing.

In addition, server platforms based on the Quad-Core Intel Xeon processor 5400 series also support many Intel® advanced server technologies that help companies enhance operations, reduce costs, and improve business continuity including:

- 12 MB of L2 cache (50% larger) for greater performance across most workloads.
- Fully Buffered DIMM (FBDIMM) technology which increases memory speed to 800 MHz and significantly improves data throughput.
- Memory mirroring and sparing which can predict a failing DIMM and copy the data to a spare memory DIMM, maintaining server availability and uptime.

## Delivering Compelling Performance Per Watt

Intel has used its new 45nm process technology to extend its Intel Core microarchitecture and deliver even higher levels of performance and density with fewer cooling challenges. The new 45nm Enhanced Intel Core microarchitecture delivers more performance in the same platforms and at the same power consumption, giving IT the flexibility to match performance, power and cost requirements with your unique requirements and delivering business and IT advantages beyond just pure performance.

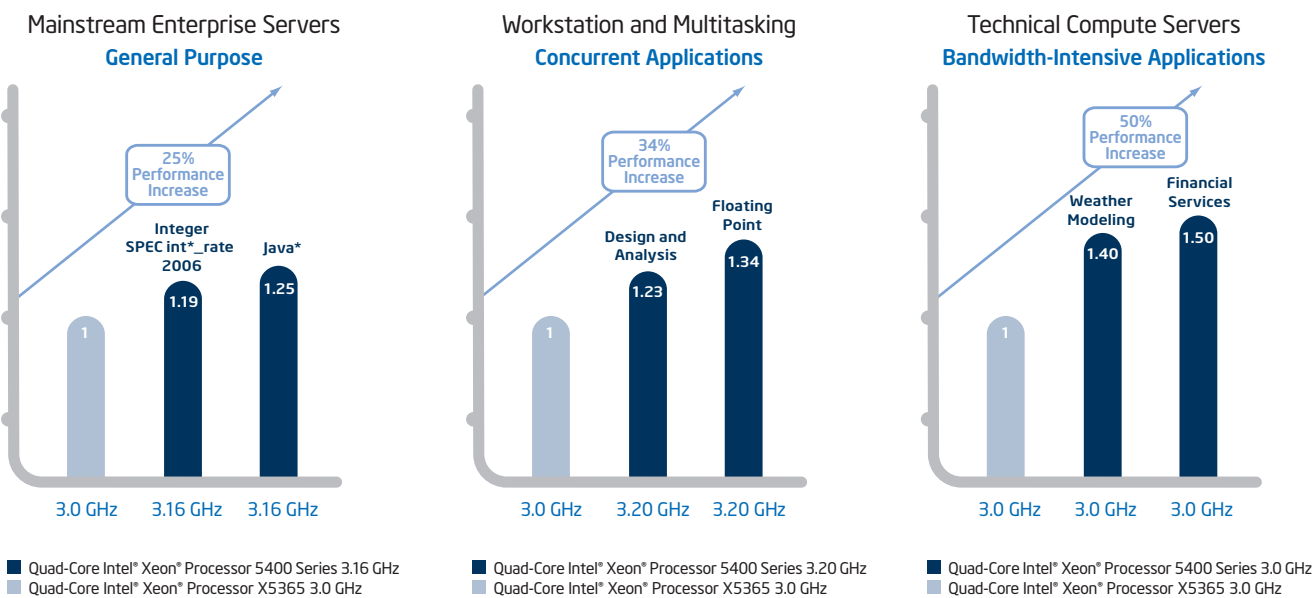

# Standard High-Volume Server

## Quad-Core or Dual-Core

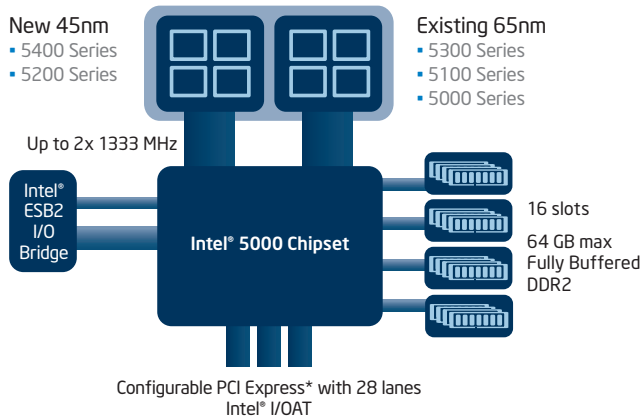

The IT platform of choice since early 2006, the newest quad-core processors, built with Intel's high-performance, energy-efficient 45nm manufacturing technology, deliver up to 25% more performance than today's leading quad-core Intel processors<sup>3</sup> in the same stable technology platform most IT professionals rely on for the broadest range of business needs across the data center, including e-mail, departmental applications, Java application servers, financial applications and more.

## The Energy Efficiency You Demand with Even More Performance and Headroom for Standard, High-Volume Servers

Servers based on the Quad-Core Intel Xeon processor 5400 series and the Enhanced Intel Core microarchitecture help companies maximize data center performance and density, and improve energy performance. Platforms based on Intel's second-generation quad-core technology make it easier to deliver more business services in existing facilities, or condense applications for more efficient operations at lower total cost of ownership (TCO).

Two-processor platforms based on the Quad-Core Intel Xeon processor 5400 series deliver 64-bit processing capabilities with 50% more cache (12 MB of L2 cache per processor), providing more computing for general purpose applications. The Quad-Core Intel Xeon processor 5400 series is ideal for dense computing environments where excellent performance and performance per watt are key requirements. The energy efficiency gained from the Intel Core microarchitecture helps enable highly dense 80-watt or 50-watt processor-based rack and blade form factors. This allows you to take back control of data center cooling, power limitations, and space constraints caused by server sprawl.

A dual-core option with a 6 MB L2 Cache is also available.

Quad-Core Intel Xeon processors 5400 series and Dual-Core Intel® Xeon® processor 5200 series utilize a common microarchitecture, common socket and common platform as existing dual-core processors and quad-core processors. This simply means that adding these new powerful, energy-efficient servers to your data center is easy and requires no software tuning and minimal hardware qualification efforts.

## Key Technologies

- 5 choices of multi-core CPUs on 1 platform
- 2 Quad- or Dual-Core Intel Xeon processors
- Power-efficient Intel® Core™ microarchitecture
- Dedicated high-speed buses per CPU
- 16 slots and up to 64 GB memory
- 28 lanes PCIe standard
- Accelerated I/O solutions

## Key Capabilities

- Exceptional performance and value for General-Purpose Servers including:
  - e-mail
  - Web
  - File
  - Business apps
- IT infrastructure virtualization

# High-Performance Computing

Built with Intel's 45nm technology and optimized for high bandwidth clusters and super computers, new HPC servers using two Quad-Core Intel Xeon processor 5400 series processors have up to 8 computational engines delivering in excess of 100GFLOPS to 64-bit applications and can deliver up to 30%<sup>4</sup> for most HPC applications and up to 50%<sup>5</sup> for optimized workloads on high compute applications over previous-generation processors.

## Technical Compute Performance: Impact Far Beyond the Data Center

At Intel, we recognize that you need more than just processors that deliver greater performance in the data center. That's why we provide platform-based solutions that maximize performance, improve throughput, and add new embedded technologies that give business, creative, and scientific professionals the tools to solve problems faster, process larger data sets, and meet bigger challenges.

Two-processor technical compute server platforms based on the Quad-Core and Dual-Core Intel Xeon processor 5400 and 5200 series integrate greater processing capabilities, faster I/O, and increased memory capacity. These multi-core servers help maximize productivity, enhance visualization, and improve flexibility to help researchers, engineers, and developers achieve more in less time.

Technical compute platforms based on the Quad-Core Intel Xeon processor 5400 series deliver 8-thread, 32- and 64-bit processing capabilities with 12 MB of L2 cache per processor, providing more computing for threaded applications in a variety of deployments. The Quad-Core Intel Xeon processor 5400 series delivers up to 30%<sup>4</sup> for most HPC applications and up to 50%<sup>5</sup> for optimized workloads over previous-generation Intel quad-core processors and with 1600 MHz Front-Side Bus (FSB), data throughput and system performance can be significantly improved.

## Quad-Core or Dual-Core

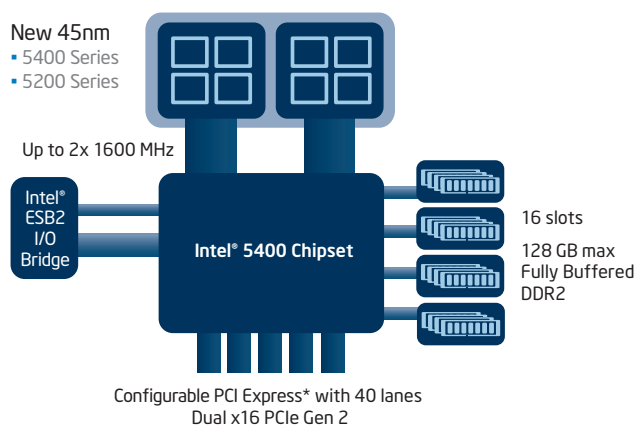

## Key Technologies

- 45nm Quad- and Dual-Core Intel Xeon processors
- 50% larger L2 cache
- 20% faster FSB (1600 MHz)
- 2x bandwidth with PCIe gen 2
- Larger memory support (up to 128 GB)
- 40 lanes of configurable PCIe (gen 1 and 2)

## Key Capabilities

- Bandwidth-intensive applications
- High-Performance Clusters
- Multi-tasking user environments

# Business Server

Optimized for small and medium business, Quad-Core Intel Xeon processors offer solid performance and performance per watt for basic business needs without sacrificing affordability. The platform is optimized for reduced cost and power consumption, featuring the Intel® 5100 chipset and native DDR2 memory. This enables you to run more applications with a smaller footprint and budget, giving you revolutionary ways to achieve more with less.

## Power and Performance for More Efficient Business

With today's competitive and budget pressures, it is critical that you get the maximum value and return from your resources. Server solutions based on Intel Xeon processors deliver powerful business capabilities at affordable prices, giving you the flexibility you need to reach new customers, increase your revenue and achieve your business goals. New 2-socket Quad-Core Intel Xeon processor 5400 series-based servers deliver new levels of performance for business processes, across a wide range of business workloads, including application servers, e-mail servers, Web servers and more.

Intel's second-generation quad-core processor, featuring a new cost optimized Intel® 5100 Memory Controller Hub Chipset, and low cost Intel ICH-9R I/O controller, and coupled with the energy efficient technology found in Intel's 45nm silicon process, enables improved IT application performance with excellent power efficiency and value. Supporting either one or two processors the platform is further optimized for reduced power consumption using low power native DDR2 memory. The high performance, low power, and affordable technology found in these new business servers helps you to run more business applications within a smaller IT footprint and giving you revolutionary ways to achieve more with less.

### Quad-Core or Dual-Core

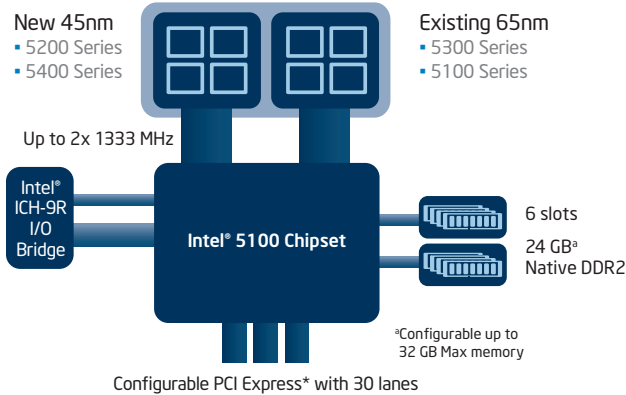

### Key Technologies

- High-performance multi-core CPUs
- Excellent investment protection
- Quad-Core and Dual-Core Intel Xeon processor capable
- Power-efficient Intel Core microarchitecture
- 6 slots of lower power DDR2 memory
- Cost-optimized chipset and I/O controller
- 30 lanes of configurable PCIe

### Key Capabilities

- Optimized for small- and medium-sized businesses seeking enterprise-class performance and quality on a constrained budget
- General-Purpose Servers including:
  - e-mail
  - Web
  - File
  - Business apps

# Workstations

Intel also offers Quad-Core and Dual-Core Intel Xeon processor-based workstations that deliver the performance and flexibility to help users solve bigger problems and create more effectively. These next-generation workstations integrate capabilities for flexibility and productivity, helping you get more done in less time, while improving user experience.

Optimized for multi-tasking environments enabling users to quickly and efficiently transform complex data into actionable information, the Intel Xeon processor 5400 series features a 1600 MHz Front-Side Bus (FSB), x16 PCIe 2 and up to 3.2 GHz CPUs.

## Built-In Efficiency for Parallel Workflows

Balanced systems based on Quad-Core and Dual-Core Intel Xeon processor 5400 and 5200 series are ideal for today's demanding applications. With more cores, a larger L2 cache, and enhanced dynamic execution engines, you can render faster, analyze and display more data with higher fidelity, and speed visual comparisons, getting up to 5x the throughput of previous-generation processors.<sup>6</sup>

Platform memory, improved store and forward algorithms, and advanced I/O also help 32- and 64-bit applications process more data faster and run more complex modeling and analyses, giving users the tools to be more productive and creative.

Technical compute servers and workstations based on Quad-Core and Dual-Core Intel® Xeon processor 5400 and 5200 series are supported by the new Intel 5400 Chipset with high performing FSB that deliver up to 1600 MHz. In addition, a 24 MB snoop filter significantly reduces data traffic on the FSB, providing lower latencies and greater available bandwidth. The snoop filter maintains an index of the current cached data in each processor, eliminating unnecessary snoops and boosting available bandwidth.

## Quad-Core or Dual-Core

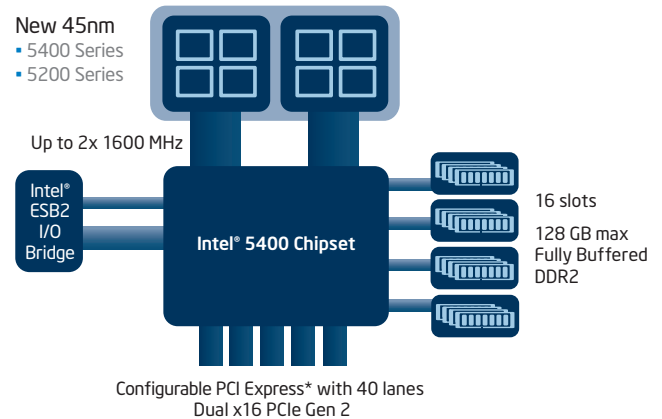

## Key Technologies

- 45nm Quad- and Dual-Core Intel Xeon processors
  - Up to 3.2 GHz quad-core, 3.4 GHz dual-core
- 20% faster FSB (1600 MHz)
- Dual x16 PCIe gen 2 graphic support
- FBDIMM 800 MHz increase memory throughput
- 24 MB snoop filter boosts available bandwidth to CPU
- Larger memory support (up to 128 GB)

## Key Capabilities

- Work with larger, more detailed complex designs
- Run multiple applications at once with good system interactivity
- Speed up individual applications, specifically those that take advantage of SMP (Symmetric Multi-Processing) and threads
- Multi-tasking user environments
- Content creation
- Graphic-intensive applications

# A Deep Look Inside the Enhanced Intel® Core™ Microarchitecture

Building on the already rich Intel® 64 instruction set architecture (ISA), Quad-Core and Dual-Core Intel Xeon processor 5400 and 5200 series have new a instruction set that help the processors to deliver superior performance and energy efficiency to a broad range of 32-bit and 64-bit applications. These new instructions include:

- **Streaming SIMD Extensions 4 (SSE4)** that will provide building blocks for delivering expanded capabilities, enhanced performance, and greater energy efficiency for many applications.
- **Application Targeted Accelerators** that will provide a new foundation for delivering low latency, lower power fixed-function capabilities for targeted applications.

These instructions represent another milestone in Intel's new cadence for the continuous development of next-generation silicon processes and processor architecture. Applications that will benefit include those involving graphics, video encoding and processing, 3-D imaging, gaming, web servers, and application servers. High-performance applications that will benefit include data mining; database; complex searching and pattern matching algorithms; audio, video, image, and data compression algorithms; parsing and state machine-based algorithms; and many more.

In addition, technical compute server platforms based on the Quad-Core Intel Xeon processor 5400 series also support many advanced technologies that help companies enhance operations, reduce costs, and speed productivity, including:

- **High-performance radix 16 dividers:** that roughly double the divider speed over previous generations for scientific computations, 3D transformations, and other mathematically intensive functions.
- **Higher Bus Speeds:** up to 1600 MHz for targeted segments such as HPC.
- **Super Shuffle Engine:** a single-pass shuffle unit that is 128-bits wide, 45nm processors can perform this full-width shuffle in a single cycle. This significantly improves performance for SSE2, SSE3 and SSE4 instructions that have shuffle-like operations such as pack, unpack and wider packed shifts, increasing performance for content creation, imaging, video, and high-performance computing.



For more information, visit  
[www.intel.com/xeon](http://www.intel.com/xeon).

# Quad-Core Intel Xeon Processor 5400 Series Overview

Two-processor technical compute servers, standard high-volume servers, entry-level business servers, and workstations based on the Quad-Core Intel Xeon processor 5400 series maximize performance and efficiency with reliability and versatility.

<b>Features</b>	<b>Benefits</b>
<b>Multi-core Processing</b>	<ul style="list-style-type: none"><li>▪ 45nm technology boosts performance on a range of workloads.</li><li>▪ Increased headroom for multi-threaded applications and heavy multi-tasking scenarios.</li><li>▪ Helps boost system utilization through virtualization<sup>1</sup> and application responsiveness.</li><li>▪ Quad-core performance and cost/virtual machines.</li><li>▪ Platform-compatible with other Quad-Core and Dual-Core Intel® Xeon® processors for ease of migration and IT stability.</li></ul>
<b>Enhanced Intel® Core™ Microarchitecture</b>	<ul style="list-style-type: none"><li>▪ Boosts performance on multiple applications/user environments and data-demanding workloads, while enabling denser data center deployments through improved performance per watt.</li><li>▪ The new 45nm Enhanced Intel Core microarchitecture delivers up to 38% more performance per watt in the same platforms and at the same system power level.<sup>7</sup></li><li>▪ Reduced idle processor power, lowers average server power consumption</li></ul>
<b>Large 12 MB of on-die L2 Cache (2 x 6MB)</b>	<ul style="list-style-type: none"><li>▪ Increases efficiency of L2 Cache-to-core data transfers, maximizing main memory to processor bandwidth.</li><li>▪ Reduces latency by storing larger data sets closer to the processor, reducing the number of trips to main memory.</li><li>▪ Up to 6 MB of L2 Cache can be allocated to one core.</li></ul>
<b>Intel® Virtualization Technology<sup>1</sup></b>	<ul style="list-style-type: none"><li>▪ A suite of processor enhancements that assists virtualization software to deliver more efficient virtualization solutions and greater capabilities including 64-bit guest OS support.</li><li>▪ Intel® VT FlexPriority, a new Intel® VT extension that optimizes virtualization software efficiency by improving interrupt handling.<sup>2</sup></li><li>▪ Intel® VT FlexMigration enables Intel Xeon processor 5400 and 5200 series-based systems to be added to the existing virtualization pool with single, 2, or 4+ socket Intel Core microarchitecture-based servers.</li></ul>
<b>Enhanced Front-Side Bus</b>	<ul style="list-style-type: none"><li>▪ New dedicated high-speed bus design enables increased throughput and bandwidth between each of the processors and the chipset.</li><li>▪ Supporting up to 1600 MHz depending on chipset.</li></ul>
<b>Intel® 64 Architecture<sup>8</sup></b>	<ul style="list-style-type: none"><li>▪ Flexibility for 64-bit and 32-bit applications and operating systems.</li></ul>

# What is the 5000 Sequence?

At Intel, our processor series numbers are intended to help clarify processor features, capabilities and intended usages. Intel offers four processor number sequences for server applications:

**Quad-Core and Dual-Core Intel® Xeon® processor 3000 sequence** One-processor servers for small business, entry, or first server based on the Intel Xeon processor.

**Quad-Core and Dual-Core Intel® Xeon® processor 7000 sequence** Greater scalability with 4- to 32-processor enterprise servers based on the Intel Xeon processor.

**Quad-Core and Dual-Core Intel® Xeon® processor 5000 sequence** Two-processor general-purpose, standard high-volume servers, HPC systems, and workstations based on the Intel Xeon processor.

**Dual-Core Intel® Itanium® processor 9000 sequence** Maximum performance and scalability for RISC replacement usage with 2- to 512-processor servers.

## Quad-Core Intel® Xeon® Processor 5400 Series

The Quad-Core Intel Xeon processor 5400 series is available in a range of features to match different computing demands. All processors integrate Intel Virtualization Technology and Intel® 64 Architecture,<sup>3</sup> and are available in the LGA771 packaging. Dual-core SKU options are also available. Intel Virtualization Technology, Intel FlexMigration, Intel FlexPriority and Intel 64 Architecture are standard on all SKUs. With the exception of E5405, all SKUs also support Demand Based Switching.

Processor Number <sup>A</sup>	CPU Frequency	L2 Cache	Front-Side Bus Speed	Power <sup>B</sup>	Number of Cores
Quad-Core Intel® Xeon® Processor X5482 <sup>a</sup>	3.20 GHz	12 MB	1600 MHz	150W	4
Quad-Core Intel® Xeon® Processor X5472	3.00 GHz	12 MB	1600 MHz	120W	4
Quad-Core Intel® Xeon® Processor E5472	3.00 GHz	12 MB	1600MHz	80W	4
Quad-Core Intel® Xeon® Processor E5462	2.80 GHz	12 MB	1600 MHz	80W	4
Quad-Core Intel® Xeon® Processor X5460	3.16 GHz	12 MB	1333 MHz	120W	4
Quad-Core Intel® Xeon® Processor X5450	3.00 GHz	12 MB	1333 MHz	120W	4
Quad-Core Intel® Xeon® Processor E5450	3.00 GHz	12 MB	1333 MHz	80W	4
Quad-Core Intel® Xeon® Processor E5440	2.83 GHz	12 MB	1333 MHz	80W	4
Quad-Core Intel® Xeon® Processor E5430	2.66 GHz	12 MB	1333 MHz	80W	4
Quad-Core Intel® Xeon® Processor E5420	2.50 GHz	12 MB	1333 MHz	80W	4
Quad-Core Intel® Xeon® Processor E5410	2.33 GHz	12 MB	1333 MHz	80W	4
Quad-Core Intel® Xeon® Processor E5405	2.00 GHz	12 MB	1333 MHz	80W	4
Dual-Core Intel® Xeon® Processor X5272	3.40 GHz	6 MB	1600 MHz	80W	2
Dual-Core Intel® Xeon® Processor X5260	3.33 GHz	6 MB	1333 MHz	80W	2
Dual-Core Intel® Xeon® Processor E5205	1.86 GHz	6 MB	1066 MHz	65W	2

<sup>a</sup>Workstation only

<sup>b</sup>50W Quad-Core and 40W Dual-Core versions will be able in first quarter, 2008.

# Systems Designed for Your Needs

## High-Performance Computing Systems and Workstation: Intel® 5400 Chipset

The Intel® 5400 chipset improves data movement across Quad-Core Intel Xeon Processor 5400 series-based workstations and HPC systems by increasing interconnect bandwidth, optimizing system bandwidth, increasing memory capacity, and improving network traffic processing while reducing I/O latency. These platform advancements help to match the improved performance of the Quad-Core Intel Xeon processor 5400 series and include a 1600 MHz Front-Side Bus, a 24 MB Snoop Filter to reduce traffic on the Front-Side Bus, and support for dual x16 PCIe gen 2 ports to support I/O-intensive applications.

## Entry-Level Business Servers: Intel® 5100 Chipset

The new Intel® 5100 MCH Chipset supports both quad- and dual-core computing and is ideal for small and medium businesses. The chipset offers energy-efficient performance and the reliability you need. With Intel® Virtualization, DDR2, PCI Express\*, serial ATA RAID, Intel® Active Management Technology<sup>3</sup> and 1066/1333 MHz DIB to improve network traffic processing.

## Standard, High-Volume Servers: Intel® 5000p or 5000v Chipsets

Widely deployed since mid-2006 for enterprise and business with existing Quad-Core and Dual-Core Intel Xeon processors, two chipset versions enable flexible server configuration to meet your goals.

**Performance: Intel® 5000p chipset** – This chipset supports 1066 and 1333 MHz system bus speeds, three PCI Express x8 links (each configurable as two x4 links), FBDIMM 533 and 667 technology, point-to-point connection for Intel® 6321 ESB I/O Controller Hub at 2 GB/s, and Intel® 6700PXH 64-bit PCI hub.

**Value: Intel® 5000v chipset** – This chipset supports 1066 and 1333 MHz system bus speeds, one PCI Express x8 link (configurable as two x4 links), FBDIMM 533 and 667 technology, point-to-point connection for Intel® 6321 ESB I/O Controller Hub at 2 GB/s, and Intel® 6700PXH 64-bit PCI hub.



## Performance Results

### Mainstream Enterprise Servers

SPECjbb2005\*: X5460 vs X5365 - Published/measured results on SPECjbb2005\* - Oct 2, 07

Comparison between 5160, X5365 and X5450 based on SPECjbb2005 benchmark result

Quad-Core Intel® Xeon® processor X5365 based platform details: Dell PowerEdge® 1950 platform with two Quad-Core Intel Xeon processor X5365 3.0GHz, 2x4Mb L2 Cache, 1333 MHz system bus, 16GB Memory DDR2-667 FBDIMM, Microsoft Windows Server 2003 Enterprise x64 Edition SP1 (64-bit), BEA JRockit 5.0 P272.0. Measured at 238,472 bops and 59,618 bops/JVM. For more information see <http://www.spec.org/jbb2005/results/res2007q3/jbb2005-20070810-00346.html>

Quad-Core Intel® Xeon® processor X5460 based platform details: Intel Server pre-production platform with two Quad-Core Intel Xeon processor X5460 3.16GHz, 2x6Mb L2 Cache, 1333 MHz system bus, 16GB Memory DDR2-667 FBDIMM, Microsoft Windows Server 2003 Enterprise x64 Edition SP1 (64-bit), BEA JRockit 5.0 P272.0. Intel internal measurement - September 2007

SPECint\*\_rate2006: X5460 vs X5365 - Published/measured results on SPECint\*\_rate2006 - Oct 2, 07 with 64-Bit SUSE LINUX Enterprise Server 10 16GB (8x2GB). SPEC binaries built with Intel Compiler 10.1 for 32-bit/64-bit Linux

Quad-Core Intel Xeon 5400 Series based platform ("Bensley/Harpertown") common configuration details: Intel server pre-production platform with two Quad-Core Intel Xeon Processor X5460 (3.16GHz) w/ 2x6M L2 Cache, 1333 MHz FSB, 5000p "Blackford" Chipset. All measurements use FB DDR2-667 MHz memory

Quad-Core Intel Xeon 5300 Series based platform ("Bensley/Clovertown") common configuration details: Intel server pre-production platform with two Quad-Core Intel Xeon Processor X5365 (3.00GHz) w/ 2x4M L2 Cache, 1333 MHz FSB, 5000p "Blackford" Chipset. All measurements use FB DDR2-667 MHz memory

Workstations: Workstation and Multi-Tasking Enhancements

SPECfp\_rate2006

Quad-Core Intel Xeon processor X5365 based platform details: Supermicro® X7DB8 with two Quad-Core Intel Xeon processors X5365 3.0GHz, 16 GB memory (8x2GB), 1333 FSB, O/S 64-Bit SUSE Linux Enterprise Server 10, Kernel 2.6.16.21-0.8-smp for x86\_64, Intel C++ Compiler for Linux version 10.1 & Smart Heap Library Version 8.1. Published at [www.spec.org](http://www.spec.org) as of September 4th 2007 at 66.9.

45nm Hi-k Intel Xeon Quad-Core processor 3.20GHz based platform details: Intel pre-production platform with two 45nm Hi-k Intel Xeon Quad-Core processors 3.20GHz, 1600 FSB, 16 GB memory (8x2GB), O/S 64-Bit SUSE Linux Enterprise Server 10, Kernel 2.6.16.21-0.8-smp for x86\_64, Intel C++ Compiler for Linux version 10.1 & Smart Heap Library Version 8.1. Result measured at 89.8.

Manufacturing "Working Differently" scenario SPECcapc\* SolidWorks\* 2005 and Fluent\* 6.3.26 L1/L2 workloads running 5x concurrently

2x Quad-Core Intel® Xeon® Processor 5400-series (3.20 GHz, 1600 MHz FSB, 12 MB cache, formerly "Harpertown") on "SunCity Stoakley" pre-production workstation compared to 2x Quad-Core Intel Xeon Processor X5365 (3.00 GHz, 1333 MHz FSB, 8 MB cache) on SuperMicro® X7DA8 workstation, COMMON: 8 GB FBD-667 memory, WDC WD740GD HDD, Windows XP® Professional x64 SP1, NVIDIA® Quadro® FX 4500 PCIe\* x16 video card driver 91.36.

### Technical Compute Servers

Weather Modeling (National Weather Services Application) and Financial Services (Black-Scholes application) running 8 threads with Red Hat EL4-U4 64-bit; 2.6.9-42.ELsmp Quad-Core Intel Xeon 5300 Series based platform ("Bensley/Clovertown") common configuration details: Intel server pre-production platform with two Quad-Core Intel Xeon Processor X5365 (3.00GHz) w/ 2x4M L2 Cache, 1333 MHz FSB, 5000p "Blackford" Chipset. All measurements use 32GB (16x2GB) FB DDR2-667 MHz memory

Quad-Core Intel Xeon 5400 Series based platform ("Stoakley/Harpertown") common configuration details: Intel server pre-production platform with two Quad-Core Intel Xeon Processor X5472 (3.0GHz) w/ 2x6M L2 Cache, 1600 MHz FSB, 5xxx "Seaburg" Chipset. All measurements use 16GB (16x1GB) FB DDR2-800 MHz memory

Performance and competitive information is accurate at the time of document publication. For the latest performance and competitive information, visit [www.intel.com/performance](http://www.intel.com/performance).

<sup>4</sup>Intel® processor numbers are not a measure of performance. Processor numbers differentiate features within each processor series, not across different processor sequences. See [http://www.intel.com/products/processor\\_number](http://www.intel.com/products/processor_number) for details.

<sup>1</sup>Intel Virtualization Technology requires a computer system with a processor, chipset, BIOS, virtual machine monitor (VMM) and applications enabled for virtualization technology. Functionality, performance or other virtualization technology benefits will vary depending on hardware and software configurations. Virtualization technology-enabled BIOS and VMM applications are currently in development.

<sup>2</sup>Intel internal measurement. Platforms running 4 x Intel® Xeon® Processor X7350, 32GB memory, vConsolidate Beta 2, Virtual Iron 4.0.2 software. 1 CSU configuration, Sept 2007. Boot time improvement measured on Windows XP. vConsolidate measurement conducted by configuring the system with Windows 2000 SP4

<sup>3</sup>Quad-Core Intel® Xeon® Processor 5300 Series ("CTN")Up to 25% (1.25x) higher Performance for Intel Xeon processor X5460 vs Intel Xeon processor X5365 - Published/measured results on SPECjbb2005\* - Oct 2, 07. Quad-Core Intel® Xeon® processor X5365 based platform details: Dell PowerEdge® 1950 platform with two Quad-Core Intel Xeon processor X5365 3.0GHz, 2x4Mb L2 Cache, 1333 MHz system bus, 16GB Memory DDR2-667 FBDIMM, Microsoft Windows Server 2003 Enterprise x64 Edition SP1 (64-bit), BEA JRockit 5.0 P272.0. Measured at 238,472 bops and 59,618 bops/JVM. For more information see <http://www.spec.org/jbb2005/results/res2007q3/jbb2005-20070810-00346.html> Quad-Core Intel® Xeon® processor X5460 based platform details: Intel Server pre-production platform with two Quad-Core Intel Xeon processor X5460 3.16GHz, 2x6Mb L2 Cache, 1333 MHz system bus, 16GB Memory DDR2-667 FBDIMM, Microsoft Windows Server 2003 Enterprise x64 Edition SP1 (64-bit), BEA JRockit 5.0 P272.0. Intel internal measurement - September 2007

<sup>4</sup>Source: Intel measured results Oct 2, 2007 for SPECfp\_rate\_base2006\* comparing Xeon X5472 (3.0GHz/12M L2 Cache/1600 MHz FSB, 5400 Chipset (pre-production platform) to Xeon X5365 (3.00GHz/8M L2 Cache/1333 MHz FSB). 2 (up to 50%) Source: Intel measured results Oct 2, 2007 for Financial Services (Black-Scholes application) running 8 threads with Red Hat EL4-U4 64-bit; 2.6.9-42.ELsmp comparing Quad-Core Intel Xeon 5300 Series based platform X5365 (3.00GHz/8M L2 Cache/1333 MHz FSB) to pre-production Quad-Core Intel Xeon 5400 Series based platform X5472 (3.0GHz/12M L2 Cache/1600 MHz FSB, 5400 Chipset (pre-production platform)

<sup>5</sup>Based on measured result on SPECfp\*\_rate2006 benchmark. SPEC binaries built with Intel Compiler 10.1 for 64-bit Linux. Servers are configured with 64-Bit SUSE LINUX Enterprise Server 10 and 16GB (8x2GB) of memory.

<sup>6</sup>Intel internal measurement as of May 10, 2007 using SPECint\_rate\_base2000\* with Intel Xeon Tigerton Processor 2.93GHz. Results compare Intel measured Quad-Core Intel Xeon Tigerton Processor (2.66GHz) or (2.93GHz), with 2x4M L2 Cache, 1066 MHz system bus, Clarksboro Chipset vs. published Dual-Core AMD Opteron® Model 8220SE (2.8SkTF).

<sup>7</sup>Intel Server pre-production platform with two Quad-Core Intel Xeon processor E5450 3.0GHz, 2x6Mb L2 Cache or E5335, 2x4MB L2 Cache, 1333 MHz system bus, 16GB Memory DDR2-667 FBDIMM, Microsoft Windows Server 2003 Enterprise x64 Edition SP1 (64-bit), BEA JRockit 5.0 P272.0. Intel internal measurement - September 2007. Perf/Watt calculated by dividing the Performance by measured system power during steady state window.

<sup>8</sup>64-bit computing on Intel architecture requires a computer system with a processor, chipset, BIOS, operating system, device drivers and applications enabled for Intel® 64 architecture. Performance will vary depending on your hardware and software configurations. Consult with your system vendor for more information.

<sup>9</sup>Intel® Active Management Technology requires the platform to have an Intel® AMT-enabled chipset, network hardware and software, as well as connection with a power source and a corporate network connection. With regard to notebooks, Intel AMT may not be available or certain capabilities may be limited over a host OS-based VPN or when connecting wirelessly, on battery power, sleeping, hibernating or powered off. For more information, see [www.intel.com/technology/platform-technology/intel-amt/](http://www.intel.com/technology/platform-technology/intel-amt/)

\*Other names and brands may be claimed as the property of others.

Copyright © 2007 Intel Corporation. All rights reserved. Intel, the Intel logo, Intel. Leap ahead., Intel. Leap ahead. logo, Xeon, Intel Core, and Itanium are trademarks of Intel Corporation in the U.S. and other countries.

